



**Give your life a lift<sup>®</sup>**  
Enjoy the home you love



**'With a tailor-made Acorn Stairlift you can stay right where you are – keep your home, and keep your freedom.'**





## Contents

---

Introduction	<b>Page 4</b>
A simple solution	<b>Page 7</b>
What kind of staircase do you have?	<b>Page 9</b>
You are in good hands	<b>Page 11</b>
Dr H Jones' Guide to buying a stairlift	<b>Page 12</b>
Product features	<b>Page 14</b>
Complete peace of mind	<b>Page 16</b>
Leading the way	<b>Page 18</b>



## Introduction

---

Your home is a cherished part of your life: a place to welcome your family and friends, to entertain, enjoy and simply relax. It is the perfect place for you.

It is a simple truth that staying in your own home gives you a wonderful feeling of independence. The freedom to move around easily and without fuss makes all the difference. So, why let getting up and down your stairs stop you from having a fully independent lifestyle?



With a tailor-made Acorn Stairlift you can stay in your home, and continue to enjoy your independence.

At Acorn we want to make sure that you get the perfect stairlift solution for your needs. With this in mind we asked Dr H Jones for his professional medical advice.

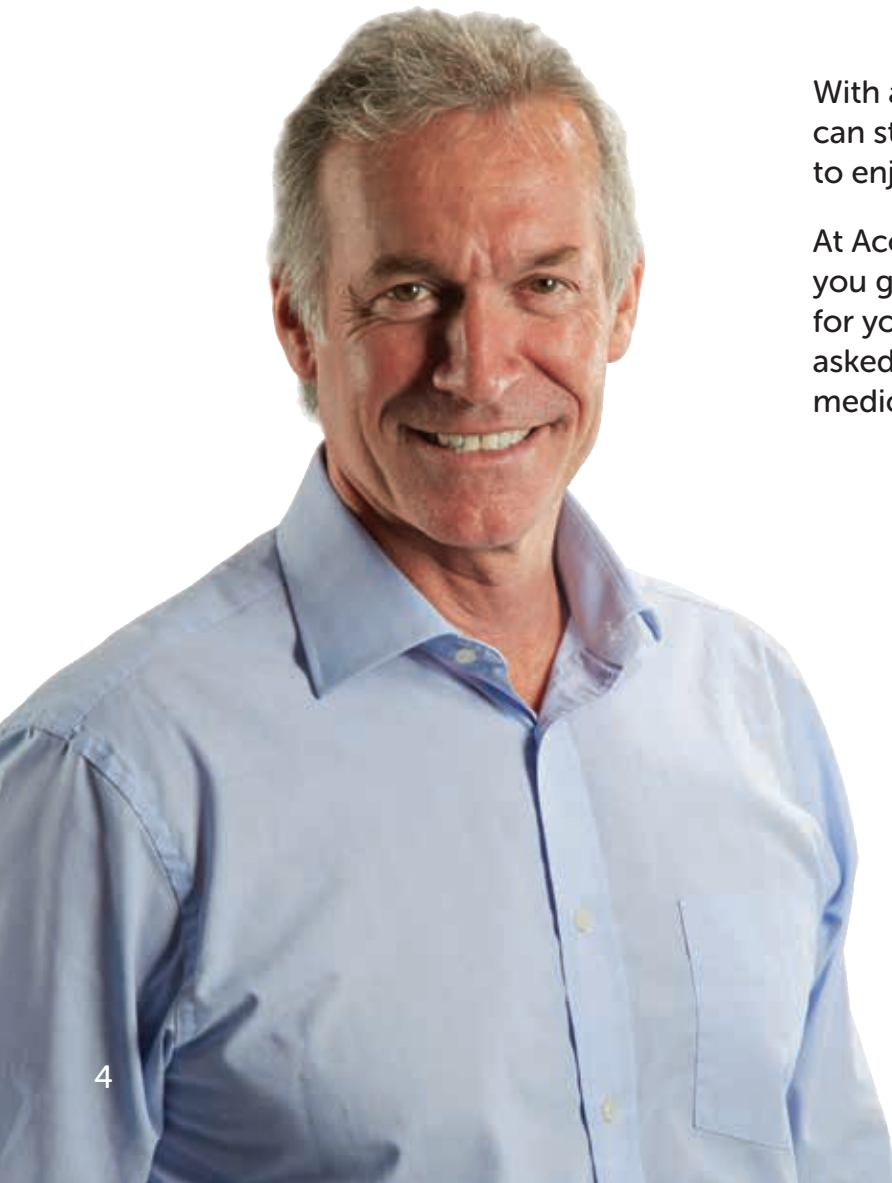

Dr H Jones

'If you know what to look for, buying a stairlift should be no more difficult than buying a new washing machine.'

.....  
**Dr Hilary Jones**





'Always opt for a stairlift that begins to travel and stops with such smoothness that you hardly even notice.'



## A simple solution

.....

An Acorn Stairlift gives you a safe, comfortable and simple way to get up and down your stairs.

Each Acorn Stairlift is tailor-made to suit your individual home and lifestyle. They are designed for fast installation with a range of cleverly engineered features that make them quick and simple for us to install and more importantly for you to use.

The unique rail system means that an Acorn Stairlift can be fitted to all types of staircase, and what's more, it can be done within a matter of days rather than weeks.

A visit from one of our representatives will allow you to see what sets Acorn Stairlifts apart from any other stairlift company. After assessing your needs our representative will instantly be able to give you the peace of mind of knowing exactly how affordable an Acorn Stairlift can be.

Acorn Stairlifts are precision manufactured, and designed and assembled in the UK. They are fitted by qualified Installation Engineers, with all work conforming to the highest safety standards. These are just a few reasons why Acorn have hundreds of thousands of happy customers throughout the world.

**'Staying in your own home gives you a wonderful feeling of independence.'**





'A simple switch or paddle control makes operating your stairlift simplicity itself.'





## What kind of staircase do you have?

.....

Because every staircase is different, Acorn Stairlifts have been developed to be highly adaptable.

Whatever type of staircase you have in your home, straight or curved, Acorn can provide the perfect solution for your needs.



## The Acorn Straight Stairlift

.....

Acorn's Straight Stairlift takes advantage of a single rail fitted to your staircase.

Acorn's slimline design means maximum space saving efficiency on your staircase, leaving plenty of room for the rest of your family to make use of the stairs.

## The Acorn Curved Stairlift

.....

Many staircases have turns, landings, or limited space at the top or bottom. Where this is the case it is often necessary for a curved stairlift to be used.

The Acorn Curved Stairlift uses a unique modular rail system which follows the profile of your staircase closely, and dramatically reduces installation time.



'Make life easy for yourself by choosing a model with a swivel seat; it's a real help.'





## You are in good hands

.....

We want to make sure you get the very best from your Acorn Stairlift from the very first time you use it, and for many years to come. From the moment your stairlift is installed, you'll know that you're in good hands.



Attention to detail during installation ensures that your stairlift is fitted precisely to your staircase, and takes up the minimum amount of space.



All of the stairlift features are double checked and then demonstrated to you by the expert installer to give you complete peace of mind.



Our unique modular rail system enables Acorn to deliver the ultimate in safety and reduces installation time.



Installers make sure they are 100% happy that they have achieved the very best solution for your staircase.

## Dr Hilary Jones' Guide to buying your stairlift

---

We asked Dr Hilary Jones what he thought was important to consider when buying a stairlift and what key benefits you should be looking out for. He has made a handy guide for you to follow to help you make the correct choice.

- 1** It is vital that your stairlift has safety sensors which automatically cut off power to the lift when the sensors are activated.
- 2** Make life easy for yourself by choosing a model with a swivel seat; it's a real help.
- 3** Always opt for a stairlift that begins to travel and stops with such smoothness that you hardly even notice.
- 4** DC power means that in the event of a power cut your stairlift won't shudder to a halt, but continue to travel.
- 5** A remote control allows you to simply call and send the stairlift, so that if a friend or partner should wish to use the lift, you can send it back to them once you've used it.
- 6** A simple switch or paddle control makes operating your stairlift simplicity itself, with no fuss or fiddling about.
- 7** A safety belt gives one extra measure towards peace of mind.
- 8** Look for a stairlift that has a digital display, this will allow you to diagnose any simple faults that may occur.

'If you or your loved ones have difficulty with the stairs then a stairlift can make a 'huge difference' to your life.'







Safety sensors automatically cut off power when activated.



Make life easy for yourself with a swivel seat stairlift.



A remote control allows you to call and send the stairlift.



A simple switch or paddle control makes operating your stairlift easier.



A safety belt gives one extra measure towards peace of mind.



A digital display will allow you to diagnose any simple faults.

'Acorn Stairlifts are precision designed and manufactured in the UK, and custom assembled to fit your home.'

## Straight Stairlift



## Curved Stairlift



## Features of Acorn Stairlifts

1. A padded seat and backrest give you comfort and extra support.
2. Directional paddle switches give you complete control. They can be operated with the lightest of touches so are perfect should you have limited dexterity.
3. An inertia safety belt is fitted to all of our stairlifts so you feel secure at all times.
4. Our slim fold away design has folding arms, seat and footrest so other people in your home can continue to use the stair case as normal.
5. A lockable swivel seat means you can get on and off your stairlift without twisting your body. Once turned it also provides a stable base and guard at the top of your stairs.
6. Direct fixture to your stairs means that there's no mess, no fuss and no need for any structural alterations or repairs.
7. A lockable on/off switch provides additional "child friendly" safety.
8. A diagnostic digital display allows you to see the exact status of the stairlift at all times.
9. Five safety sensors on the footrest and carriage stop the lift automatically and very gently should there be any obstruction on your staircase.
10. Two remote controls are provided so that you have the convenience of being able to call or send the lift up or down the staircase.



## Dimensions

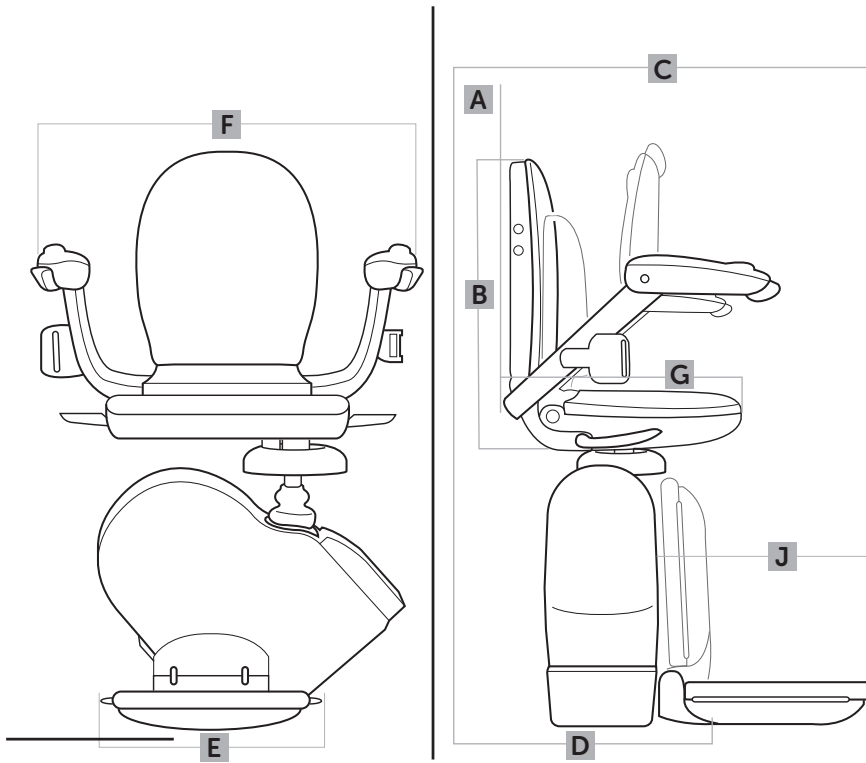

### Acorn Superglide Straight Stairlift

	<b>mm</b>
<b>A</b> Overall height (from floor)	980
<b>B</b> Height of seat	440
<b>C</b> Overall depth (from wall)	570
<b>D</b> Overall depth (when folded)	310
<b>E</b> Width of footrest	310
<b>F</b> Overall width	605
<b>G</b> Depth of seat	435

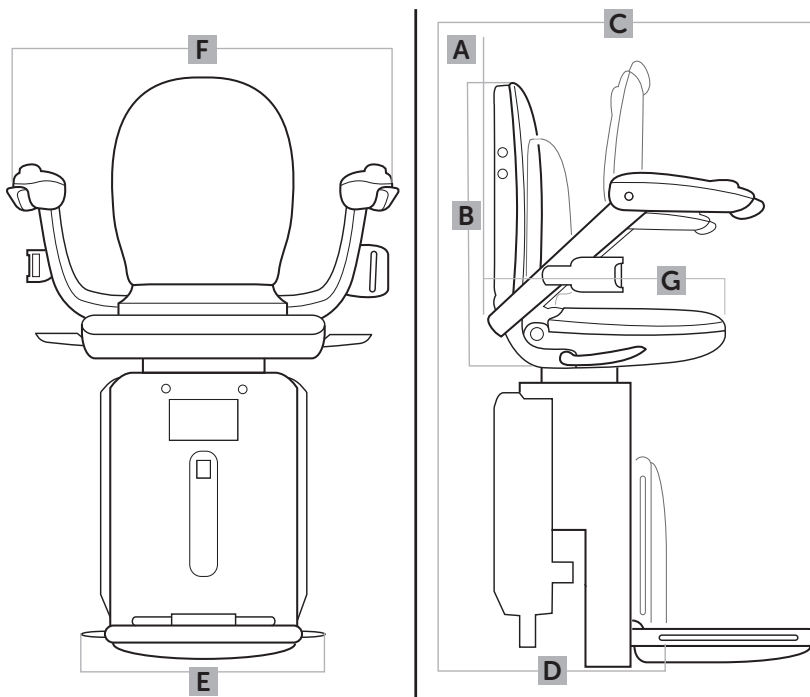

### Acorn 180 Curved Stairlift

	<b>mm</b>
<b>A</b> Overall height (from floor)	975
<b>B</b> Height of seat	440
<b>C</b> Overall depth (from wall)	640
<b>D</b> Overall depth (when folded)	335
<b>E</b> Width of footrest	360
<b>F</b> Overall width	620
<b>G</b> Depth of seat	435

## Complete peace of mind

---

Acorn has always been at the forefront of the stairlift industry, and have led the way with design and innovation, always striving to deliver products with you, the customer in mind.

Aiming to provide the perfect solution for your needs, Acorn receive many letters and recommendations from customers, a sure sign that they are achieving their goal of delivering the reliability and efficiency that people require to help them regain the freedom of their home.



## A simple solution

---

By the time you have read this brochure, Acorn will have given someone else's life a lift; because every 8 minutes, 365 days a year an Acorn Stairlift is installed somewhere in the world.



'Simple safe and stylish, Acorn Stairlifts give people the chance to enjoy their own homes again.'



## Leading the way

---



The Acorn Stairlift rail systems are manufactured at the engineering plant in the UK.



With millions of pounds worth of investment in UK manufacturing facilities, Acorn are ideally located to provide stairlifts worldwide.



Every component part is inspected and goes through numerous quality controls.



Attention to detail and precision engineering mean Acorn deliver quality and reliability to every customer.



'Regain your independence with this Great British Manufacturer'.



**Dr H Jones**

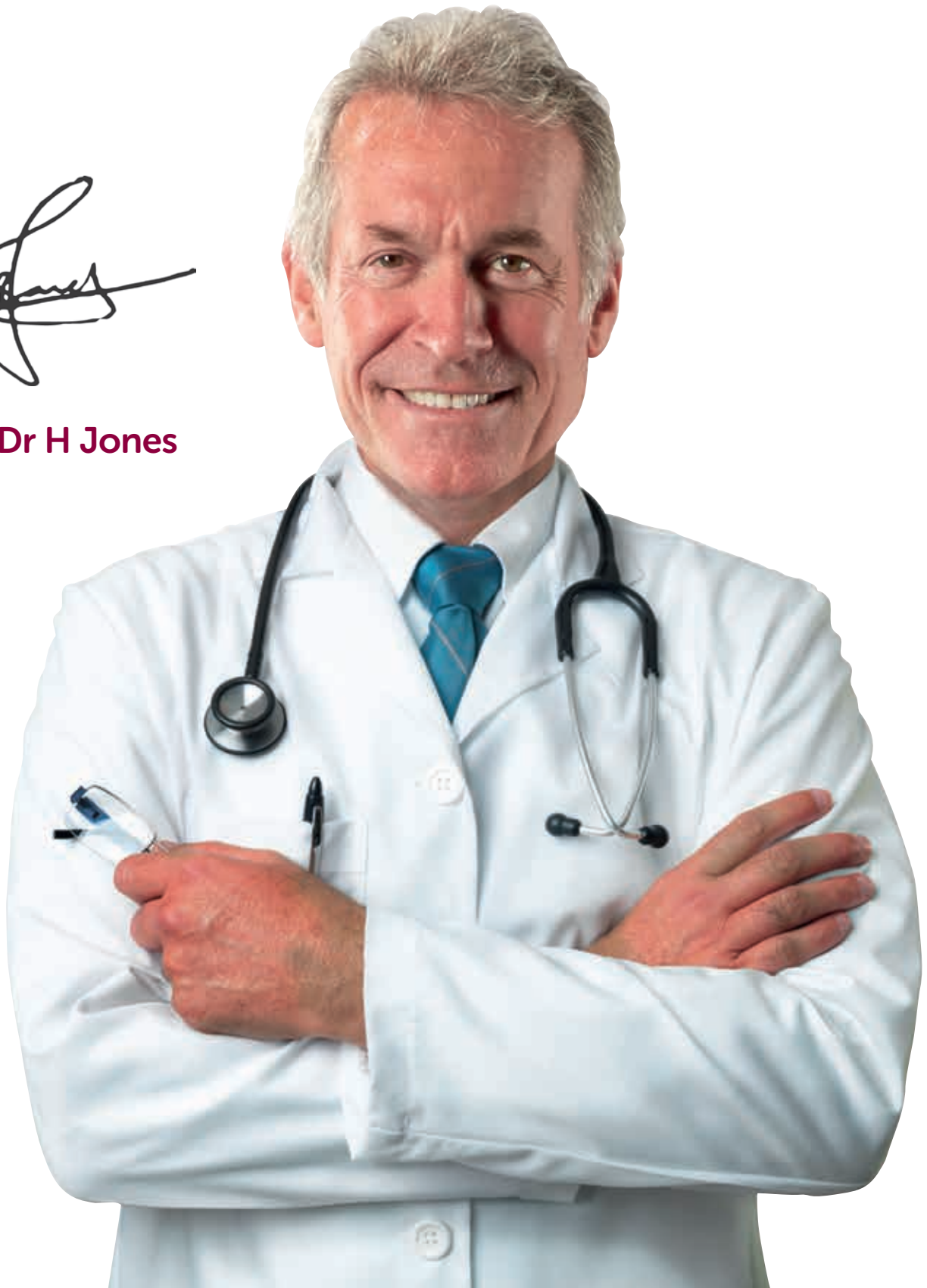



Call us today for more information  
about Acorn Stairlifts

.....

Dealer Stamp

**All materials copyright © 2016 Acorn Stairlifts Ltd. All rights reserved.**  
No part of this material may be used for any purpose without prior written permission. Use without permission is expressly prohibited by law, and may result in civil and criminal penalties. Photographs and diagrams are used for illustrative purposes only. All information including dimensions, specifications and prices are correct at time of printing and are subject to change. E&OE.  
Registered in England No. 1042173



021\_AC\_UK\_Dealer\_brochure\_1116